

Q.No. 1-25 Carry One Mark Each

1. Which of the following problems are decidable?
- 1) Does a given program ever produce an output?
 - 2) If L is context-free language, then, is \bar{L} also context-free?
 - 3) If L is regular language, then, is \bar{L} also regular?
 - 4) If L is recursive language, then, is \bar{L} also recursive?
- (A) 1,2,3,4 (B) 1,2 (C) 2,3,4 (D) 3,4

Answer: (D)

2. Given the language $L = \{ab, aa, baa\}$, which of the following strings are in L^* ?
- 1) abaabaaabaa
 - 2) aaaabaaaa
 - 3) baaaaabaaaab
 - 4) baaaaabaa
- (A) 1,2 and 3 (B) 2,3 and 4 (C) 1,2 and 4 (D) 1,3 and 4

Answer: (C)

3. In the IPv4 addressing format, the number of networks allowed under Class C addresses is
- (A) 2^{14} (B) 2^7 (C) 2^{21} (D) 2^{24}

Answer: (C)

4. Which of the following transport layer protocols is used to support electronic mail?
- (A) SMTP (B) IP (C) TCP (D) UDP

Answer: (C)

5. Consider a random variable X that takes values $+1$ and -1 with probability 0.5 each. The values of the cumulative distribution function $F(x)$ at $x = -1$ and $+1$ are
- (A) 0 and 0.5 (B) 0 and 1
(C) 0.5 and 1 (D) 0.25 and 0.75

Answer: (C)

6. Register renaming is done in pipelined processors
- (A) as an alternative to register allocation at compile time
 - (B) for efficient access to function parameters and local variables
 - (C) to handle certain kinds of hazards
 - (D) as part of address translation

Answer: (C)

7. The amount of ROM needed to implement a 4 bit multiplier is
- (A) 64 bits (B) 128 bits (C) 1 Kbits (D) 2 Kbits

Answer: (D)

8. Let $W(n)$ and $A(n)$ denote respectively, the worst case and average case running time of an algorithm executed on an input of size n . Which of the following is **ALWAYS TRUE**?
- (A) $A(n) = \Omega(W(n))$ (B) $A(n) = \Theta(W(n))$
 (C) $A(n) = O(W(n))$ (D) $A(n) = o(W(n))$

Answer: (C)

9. Let G be a simple undirected planar graph on 10 vertices with 15 edges. If G is a connected graph, then the number of **bounded** faces in any embedding of G on the plane is equal to
- (A) 3 (B) 4 (C) 5 (D) 6

Answer: (D)

10. The recurrence relation capturing the optimal execution time of the *Towers of Hanoi* problem with n discs is
- (A) $T(n) = 2T(n-2) + 2$ (B) $T(n) = 2T(n-1) + n$
 (C) $T(n) = 2T(n/2) + 1$ (D) $T(n) = 2T(n-1) + 1$

Answer: (D)

11. Which of the following statements are **TRUE** about an SQL query?
- P : An SQL query can contain a HAVING clause even if it does not have a GROUP BY clause
 Q : An SQL query can contain a HAVING clause only if it has GROUP BY clause
 R : All attributes used in the GROUP BY clause must appear in the SELECT clause
 S : Not all attributes used in the GROUP BY clause need to appear in the SELECT clause
- (A) P and R (B) P and S (C) Q and R (D) Q and S

Answer: (C)

12. Given the basic ER and relational models, which of the following is **INCORRECT**?
- (A) An attribute of an entity can have more than one value
 (B) An attribute of an entity can be composite
 (C) In a row of a relational table, an attribute can have more than one value
 (D) In a row of a relational table, an attribute can have exactly one value or a NULL value

Answer: (C)

13. What is the complement of the language accepted by the NFA show below?
 Assume $\Sigma = \{a\}$ and ϵ is the empty string.

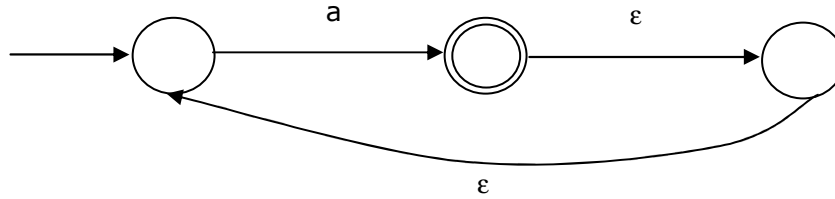

- (A) \emptyset (B) $\{\epsilon\}$ (C) a^* (D) $\{a, \epsilon\}$

Answer: (B)

14. What is the correct translation of the following statement into mathematical logic?

“Some real numbers are rational”

- (A) $\exists x (\text{real}(x) \vee \text{rational}(x))$ (B) $\forall x (\text{real}(x) \rightarrow \text{rational}(x))$
 (C) $\exists x (\text{real}(x) \wedge \text{rational}(x))$ (D) $\exists x (\text{rational}(x) \rightarrow \text{real}(x))$

Answer: (C)

15. Let A be the 2×2 matrix with elements $a_{11} = a_{12} = a_{21} = +1$ and $a_{22} = -1$. Then A^{19} are

- (A) 1024 and -1024 (B) $1024\sqrt{2}$ and $-1024\sqrt{2}$
 (C) $4\sqrt{2}$ and $-4\sqrt{2}$ (D) $512\sqrt{2}$ and $-512\sqrt{2}$

Answer: (D)

16. The protocol data unit (PDU) for the application layer in the Internet stack is

- (A) Segment (B) Datagram (C) Message (D) Frame

Answer: (C)

17. Consider the function $f(x) = \sin(x)$ in the interval $x \in [\pi/4, 7\pi/4]$. The number and location (s) of the local minima of this function are

- (A) One, at $\pi/2$ (B) One, at $3\pi/2$
 (C) Two, at $\pi/2$ and $3\pi/2$ (D) Two, at $\pi/4$ and $3\pi/2$

Answer: (B)

18. A process executes the code

```
fork ();
fork ();
fork ();
```

The total number of **child** processes created is

- (A) 3 (B) 4 (C) 7 (D) 8

Answer: (C)

19. The decimal value 0.5 in IEEE single precision floating point representation has
 (A) fraction bits of 000...000 and exponent value of 0
 (B) fraction bits of 000...000 and exponent value of -1
 (C) fraction bits of 100...000 and exponent value of 0
 (D) no exact representation

Answer: (B)

20. The truth table

X	Y	f(X,Y)
0	0	0
0	1	0
1	0	1
1	1	1

represents the Boolean function

- (A) X (B) $X + Y$ (C) $X \oplus Y$ (D) Y

Answer: (A)

21. The worst case running time to search for an element in a balanced binary search tree with $n2^n$ elements is
 (A) $\Theta(n \log n)$ (B) $\Theta(n2^n)$ (C) $\Theta(n)$ (D) $\Theta(\log n)$

Answer: (C)

22. Assuming $P \neq NP$, which of the following is **TRUE**?
 (A) NP-complete = NP (B) NP-complete \cap P = \emptyset
 (C) NP-hard = NP (D) P = NP-complete

Answer: (B)

23. What will be the output of the following C program segment?

```
Char inChar = 'A' ;
switch (inChar ) {
case 'A' : printf ("Choice A\ n");
case 'B' :
case 'C' : print f("Choice B");
case 'D' :
case 'E' :
default : printf ("No Choice") ; }
```

- (A) No choice
- (B) Choice A
- (C) Choice A
Choice B No choice
- (D) Program gives no output as it is erroneous

Answer: (C)

24. Which of the following is **TRUE**?
- (A) Every relation is 3NF is also in BCNF
 - (B) A relation R is in 3NF if every non-prime attribute of R is fully functionally dependent on every key of R
 - (C) Every relation in BCNF is also in 3NF
 - (D) No relation can be in both BCNF and 3NF

Answer: (C)

25. Consider the following logical inferences.

I_1 : If it rains then the cricket match will not be played.

The cricket match was played.

Inference: There was no rain.

I_2 : If it rains then the cricket match will not be played.

It did not rain.

Inference: The cricket match was played.

Which of the following is **TRUE**?

- (A) Both I_1 and I_2 are correct inferences
- (B) I_1 is correct but I_2 is not a correct inference
- (C) I_1 is not correct but I_2 is a correct inference
- (D) Both I_1 and I_2 are not correct inferences

Answer: (B)

Q. No. 26-51 Carry Two Marks Each

26. Consider the set of strings on $\{0,1\}$ in which, every substring of 3 symbols has at most two zeros. For example, 001110 and 011001 are in the language, but 100010 is not. All strings of length less than 3 are also in the language. A partially completed DFA that accepts this language is shown below.

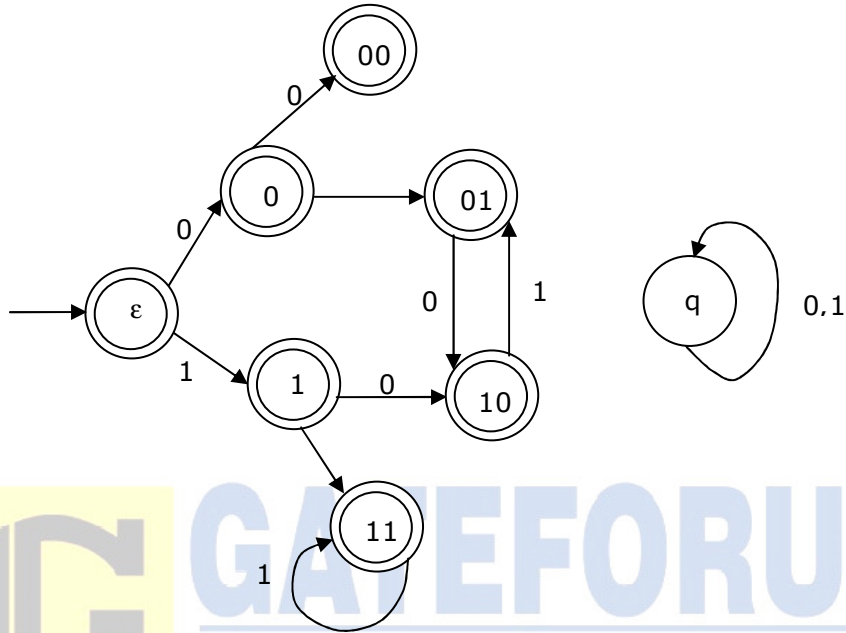

The missing arcs in the DFA are

(A)

(B)

	00	01	10	11	q
00	1	0			
01				1	
10	0				
11			0		

(C)

	00	01	10	11	q
00		1			0
01		1			
10			0		
11		0			

(D)

	00	01	10	11	q
00		0			1
01		1			
10				0	
11		0			

	00	01	10	11	q
00		1			0
01				1	
10	0				
11			0		

Answer: (D)

- 27 The height of a tree is defined as the number of edges on the longest path in the tree. The function shown in the pseudocode below is invoked as height (root) to compute the height of a binary tree rooted at the tree pointer root.

```

int height (treeptr n)
{ if (n== NULL) return -1;
  if (n → left == NULL)
    if (n → right ==NULL) return 0;
    else return [B1]; // Box 1
else {h1 = height (n → left);
      if (n → right == NULL) return (1 + h1);
      else {h2 = height (n → right);
            return [B2] ; // Box 2
          }
    }
}

```

The appropriate expressions for the two boxes B1 and B2 are

- (A) B1 : (1 + height (n → right)) (B) B1 : (height (n → right))
 B2 : (1 + max (h1, h2)) B2 : (1 + max (h1, h2))
 (C) B1 : height (n → right)
 B2 : max (h1, h2) (D) B1 : (1 + height (n → right))
 B2 : max (h1, h2)

Answer: (A)

28. Consider an instance of TCP’s Additive Increase Multiplicative decrease (AIMD) algorithm where the window size at the start of the slow start phase is 2 MSS and the threshold at the start of the first transmission is 8 MSS. Assume that a timeout occurs during the fifth transmission. Find the congestion window size at the end of the tenth transmission.

- (A) 8MSS (B) 14MSS (C) 7MSS (D) 12MSS

Answer:

29. Consider a source computer (S) transmitting a file of size 10^6 bits to a destination computer (D) over a network of two routers (R_1 and R_2) and three links (L_1 , L_2 , and L_3). L_1 connects S to R_1 ; L_2 connects R_1 to R_2 ; and L_3 connects R_2 to D. Let each link be of length 100km. Assume signals travel over each line at a speed of 10^8 meters per second. Assume that the link bandwidth on each link is 1Mbps. Let the file be broken down into 1000 packets each of size 1000

bits. Find the total sum of transmission and propagation delays in transmitting the file from S to D?

- (A) 1005ms (B) 1010ms (C) 3000ms (D) 3003ms

Answer: (A)

30. Suppose R_1 (\underline{A} , B) and R_2 (\underline{C} , D) are two relation schemas. Let r_1 and r_2 be the corresponding relation instances. B is a foreign key that refers to C in R_2 . If data in r_1 and r_2 satisfy referential integrity constraints, which of the following is **ALWAYS TRUE**?

- (A) $\Pi_B(r_1) - \Pi_C(r_2) = \emptyset$
(B) $\Pi_C(r_2) - \Pi_B(r_1) = \emptyset$
(C) $\Pi_B(r_1) = \Pi_C(r_2)$
(D) $\Pi_B(r_1) - \Pi_C(r_2) \neq \emptyset$

Answer: (A)

31. Consider the virtual page reference string

1,2,3,2,4,1,3,2,4,1

on a demand paged virtual memory system running on a computer system that has main memory size of 3 page frames which are initially empty. Let LRU, FIFO and OPTIMAL denote the number of page faults under the corresponding page replacement policy. Then

- (A) OPTIMAL < LRU < FIFO
(B) OPTIMAL < FIFO < LRU
(C) OPTIMAL = LRU
(D) OPTIMAL = FIFO

Answer: (B)

32. A file system with 300 GByte disk uses a file descriptor with 8 direct block addresses, 1 indirect block address and 1 doubly indirect block address. The size of each disk block is 128 Bytes and the size of each disk block address is 8 Bytes. The maximum possible file size in this file system is

- (A) 3 KBytes
(B) 35 KBytes
(C) 280 KBytes
(D) dependent on the size of the disk

Answer: (B)

33. Consider the directed graph shown in the figure below. There are multiple shortest paths between vertices S and T. Which one will be reported by Dijkstra's shortest path algorithm? Assume that, in any iteration, the shortest path to a vertex v is updated only when a strictly shorter path to v is discovered.

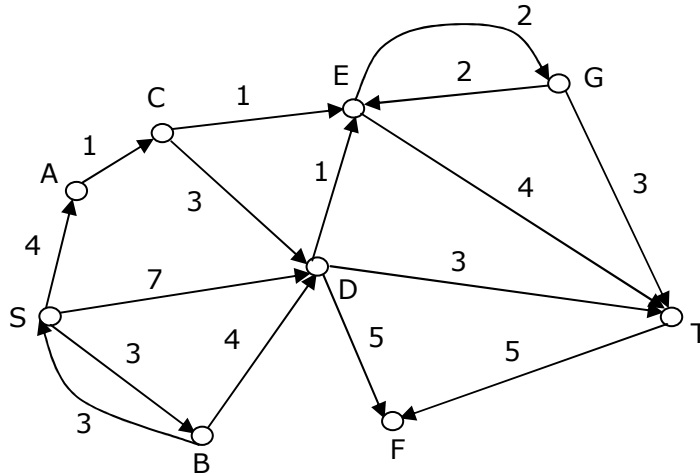

- (A) SDT (B) SBDT (C) SACDT (D) SACET

Answer: (D)

34. A list of n strings, each of length n , is sorted into lexicographic order using the merge-sort algorithm. The worst case running time of this computation is

- (A) $O(n \log n)$ (B) $O(n^2 \log n)$
(C) $O(n^2 + \log n)$ (D) $O(n^2)$

Answer: (D)

35. Let G be a complete undirected graph on 6 vertices. If vertices of G are labeled, then the number of distinct cycles of length 4 in G is equal to

- (A) 15 (B) 30 (C) 90 (D) 360

Answer: (C)

36. How many onto (or surjective) functions are there from an n -element ($n \geq 2$) set to a 2-element set?

- (A) 2^n (B) $2^n - 1$ (C) $2^n - 2$ (D) $2(2^n - 2)$

Answer: (C)

37. Consider the program given below, in a block-structured pseudo-language with lexical scoping and nesting of procedures permitted.

```

Program main;
  Var . . .
  Procedure A1;
    Var ....
    Call A2;
  End A1
  Procedure A2;

```

```

Var . . .
Procedure A21;
  Var . . .
  Call A1;
End A21
Call A21;
End A2
Call A1;
End main.
    
```

Consider the calling chain: Main → A1 → A2 → A21 → A1

The correct set of activation records along with their access links is given by

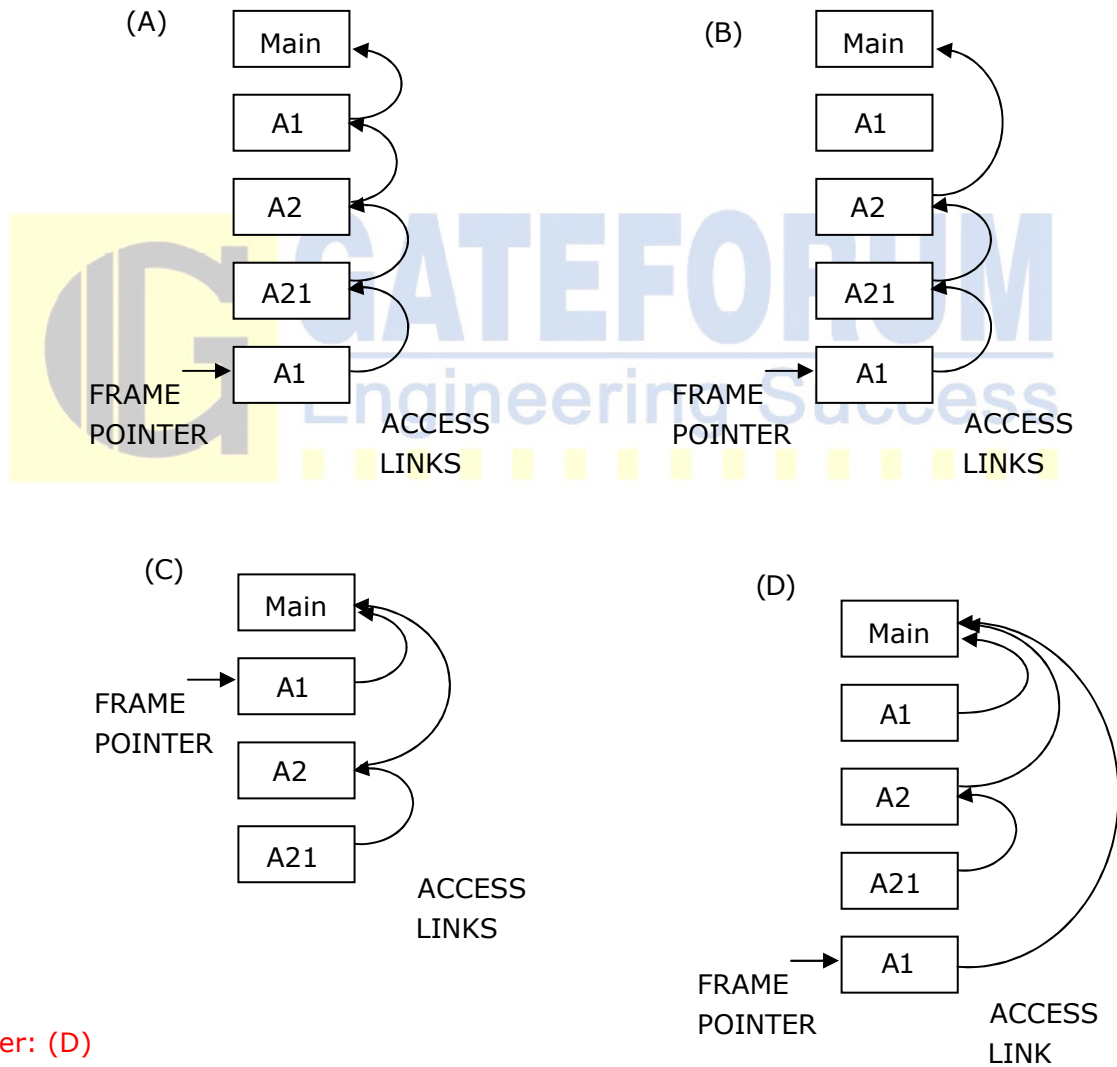

Answer: (D)

38. Suppose a circular queue of capacity $(n - 1)$ elements is implemented with an array of n elements. Assume that the insertion and deletion operations are carried out using REAR and FRONT as array index variables, respectively. Initially, REAR = FRONT = 0. The conditions to detect queue full and queue empty are
- (A) full: $(\text{REAR}+1) \bmod n == \text{FRONT}$ (A) full: $(\text{REAR}+1) \bmod n == \text{FRONT}$
empty: REAR == FRONT empty: $(\text{FRONT}+1) \bmod n == \text{REAR}$
- (C) full: REAR == FRONT (D) full: $(\text{FRONT}+1) \bmod n == \text{REAR}$
empty: $(\text{REAR}+1) \bmod n == \text{FRONT}$ empty: REAR == FRONT

Answer: (A)

39. An Internet Service Provider (ISP) has the following chunk of CIDR-based IP addresses available with it: 245.248.128.0/20. The ISP wants to give half of this chunk of addresses to Organization A, and a quarter to Organization B, while retaining the remaining with itself. Which of the following is a valid allocation of address to A and B?
- (A) 245.248.136.0/21 and 245.248.128.0/22
(B) 245.248.128.0/21 and 245.248.128.0/22
(C) 245.248.132.0/22 and 245.248.132.0/21
(D) 245.248.136.0/24 and 245.248.132.0/21

Answer: (A)

40. Suppose a fair six-sided die is rolled once. If the value on the die is 1, 2, or 3, the die is rolled a second time. What is the probability that the sum total of values that turn up is at least 6?
- (A) 10/21 (B) 5/12 (C) 2/3 (D) 1/6

Answer: (B)

41. Fetch_And_Add (X, i) is an atomic Read-Modify-Write instruction that reads the value of memory location X , increments it by the value i , and returns the old value of X . It is used in the pseudocode shown below to implement a busy-wait lock. L is an unsigned integer shared variable initialized to 0. The value of 0 corresponds to lock being available, while any non-zero value corresponds to the lock being not available.

```
AcquireLock(L){
    While (Fetch_And_Add(L,1))
        L = 1;
}
Release Lock(L){
    L = 0;
}
This implementation
```

- (A) fails as L can overflow
- (B) fails as L can take on a non-zero value when the lock is actually available
- (C) works correctly but may starve some processes
- (D) works correctly without starvation

Answer: (B)

42. Consider the 3 process, P1, P2 and P3 shown in the table.

Process	Arrival time	Time units Required
P1	0	5
P2	1	7
P3	3	4

The completion order of the 3 processes under the policies FCFS and RR2 (round robin scheduling with CPU quantum of 2 time units) are

- (A) **FCFS:** P1, P2, P3 **RR2:** P1, P2, P3
- (B) **FCFS:** P1, P3, P2 **RR2:** P1, P3, P2
- (C) **FCFS:** P1, P2, P3 **RR2:** P1, P3, P2
- (D) **FCFS:** P1, P3, P2 **RR2:** P1, P2, P3

Answer: No option matching; **FCFS:** P1, P2, P3 **RR2:** P3, P1, P2

43. What is the minimal form of the Karnaugh map shown below? Assume that X denotes a don't care term.

		ab			
		00	01	11	10
cd	00	1	X	X	1
	01	X			1
	11				
	10	1			X

- (A) $\bar{b}\bar{d}$
- (B) $\bar{b}\bar{d} + \bar{b}\bar{c}$
- (C) $\bar{b}\bar{d} + a\bar{b}\bar{c}\bar{d}$
- (D) $\bar{b}\bar{d} + \bar{b}\bar{c} + \bar{c}\bar{d}$

Answer: (B)

44. Let G be a weighted graph with edge weights greater than one and G' be the graph constructed by squaring the weights of edges in G . Let T and T' be the minimum spanning trees of G and G' respectively, with total weights t and t' . Which of the following statements is **TRUE**?
- (A) $T' = T$ with total weight $t' = t^2$
 (B) $T' = T$ with total weight $t' < t^2$
 (C) $T' \neq T$ but total weight $t' = t^2$
 (D) None of these

Answer: (D)

45. The bisection method is applied to compute a zero of the function $f(x) = x^4 - x^3 - x^2 - 4$ in the interval $[1,9]$. The method converges to a solution after _____ iterations.
- (A) 1 (B) 3 (C) 5 (D) 7

Answer: (B)

46. Which of the following graph is isomorphic to

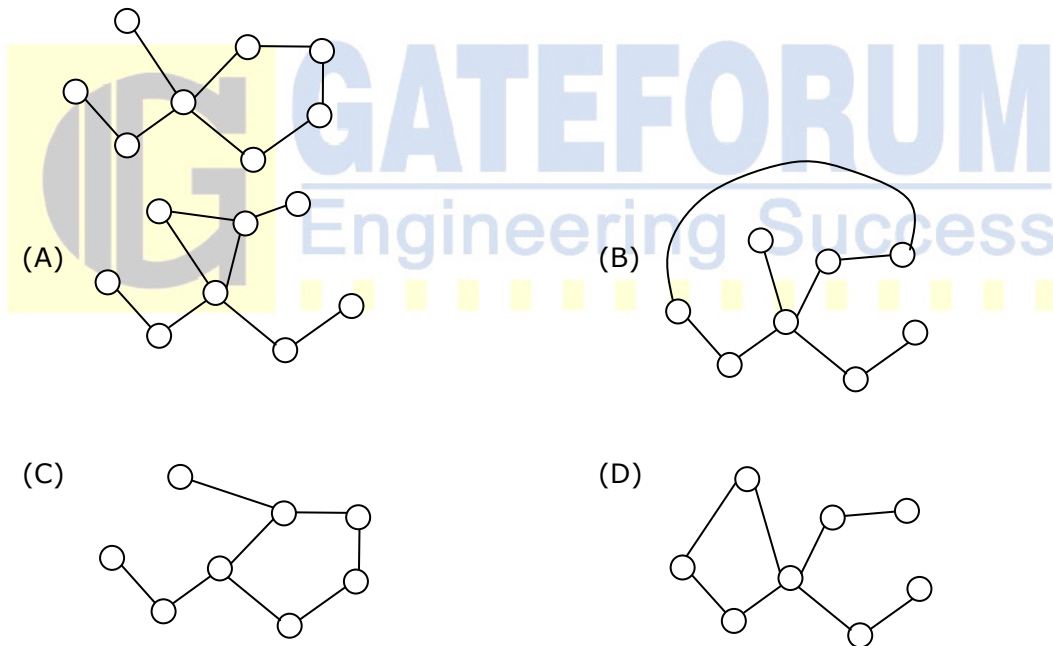

Answer: (B)

47. Consider the following transactions with data items P and Q initialized to zero:
- T_1 : read (P) ;
 read (Q) ;
 if $P = 0$ then $Q := Q + 1$;
 write (Q).
 T_2 : read (Q) ;

read (P)
if Q = 0 then P := P + 1 ;
write (P).

Any non-serial interleaving of T1 and T2 for concurrent execution leads to

- (A) a serializable schedule
- (B) a schedule that is not conflict serializable
- (C) a conflict serializable schedule
- (D) a schedule for which precedence graph cannot be drawn

Answer: (B)

Common Data Questions: 48 & 49

Consider the following relations A, B and C:

A

Id	Name	Age
12	Arun	60
15	Shreya	24
99	Rohit	11

B

Id	Name	Age
15	Shreya	24
25	Hari	40
98	Rohit	20
99	Rohit	11

C

Id	Phone	Area
10	220	02
99	2100	01

48. How many tuples does the result of the following SQL query contain?

SELECT A.Id
FROM A
WHERE A.Age > **ALL**(**SELECT** B.Age
FROM B
WHERE B.Name = 'Arun')

- (A) 4
- (B) 3
- (C) 0
- (D) 1

Answer: (B)

49. How many tuples does the result of the following relational algebra expression contain? Assume that the schema of $A \cup B$ is the same as that of A.

$$(A \cup B) \bowtie_{\langle A.Id > 40 \vee C.Id < 15 \rangle} C$$

- (A) 7 (B) 4 (C) 5 (D) 9

Answer: (A)

Common Data Questions: 50 & 51

Consider the following C code segment:

```
int a, b, c = 0;
void prtFun(void);
main( )
{
    static int a = 1;          /* Line 1 */
    prtFun( );
    a + = 1;
    prtFun( )
    printf("\n %d %d ", a, b);
}

Void prtFun(void)
{
    static int a=2;          /* Line 2 */
    int b=1;
    a+=++b;
    printf("\n %d %d ", a, b);
}
```

50. What output will be generated by the given code segment if:
Line 1 is replaced by **auto int a = 1;**
Line 2 is replaced by **register int a = 2;**

- | | | | |
|-----|-----|-----|-----|
| (A) | (B) | (C) | (D) |
| 3 1 | 4 2 | 4 2 | 4 2 |
| 4 1 | 6 1 | 6 2 | 4 2 |
| 4 2 | 6 1 | 2 0 | 2 0 |

Answer: (D)

51. What output will be generated by the given code segment?

- | | | | |
|-----|-----|-----|-----|
| (A) | (B) | (C) | (D) |
| 3 1 | 4 2 | 4 2 | 3 1 |
| 4 1 | 6 1 | 6 2 | 5 2 |
| 4 2 | 6 1 | 2 0 | 5 2 |

Answer: (C)

Linked Answer Questions: Q.52 to Q.55 Carry Two Marks Each

Statement for Linked Answer Question: 52 & 53

A computer has a 256 KByte, 4-way set associative, write back data cache with block size of 32 Bytes. The processor sends 32 bit addresses to the cache controller. Each cache tag directory entry contains, in addition to address tag, 2 valid bits, 1 modified bit and 1 replacement bit.

52. The number of bits in the tag field of an address is
 (A) 11 (B) 14 (C) 16 (D) 27

Answer: (C)

53. The size of the cache tag directory is
 (A) 160 Kbits (B) 136 Kbits (C) 40 Kbits (D) 32 Kbits

Answer: (A)

Statement for Linked Answer Question: 54 & 55

For the grammar below, a partial LL(1) parsing table is also presented along with the grammar. Entries that need to be filled are indicated as **E1**, **E2**, and **E3**. ϵ is the empty string, \$ indicates end of input, and | separates alternate right hand sides of productions.

$S \rightarrow aAbB \mid bAaB \mid \epsilon$

$A \rightarrow S$

$B \rightarrow S$

	A	b	\$
S	E1	E2	$S \rightarrow \epsilon$
A	$A \rightarrow S$	$A \rightarrow S$	error
B	$B \rightarrow S$	$B \rightarrow S$	E3

54. The First and Follow sets for the non-terminals A and B are

(A) $FIRST(A) = \{a, b, \epsilon\} = FIRST(B)$

$FOLLOW(A) = \{a, b\}$

$FOLLOW(B) = \{a, b, \$\}$

(B) $FIRST(A) = \{a, b, \$\}$

$FIRST(B) = \{a, b, \epsilon\}$

$FOLLOW(A) = \{a, b\}$

$FOLLOW(B) = \{\$\}$

(C) $\text{FIRST}(A) = \{a, b, \epsilon\} = \text{FIRST}(B)$

$\text{FIRST}(A) = \{a, b\}$

$\text{FOLLOW}(B) = \emptyset$

(D) $\text{FIRST}(A) = \{a, b\} = \text{FIRST}(B)$

$\text{FIRST}(A) = \{a, b\}$

$\text{FOLLOW}(B) = \{a, b\}$

Answer: (A)

55. The appropriate entries for E1, E2, and E3 are

(A) E1: $S \rightarrow aAbB$, $A \rightarrow S$

(B) E1: $S \rightarrow aAbB$, $S \rightarrow \epsilon$

E2: $S \rightarrow bAaB$, $B \rightarrow S$

E2: $S \rightarrow bAaB$, $S \rightarrow \epsilon$

E3: $B \rightarrow S$

E3: $S \rightarrow \epsilon$

(C) E1: $S \rightarrow aAbB$, $S \rightarrow \epsilon$

(D) E1: $A \rightarrow S$, $S \rightarrow \epsilon$

E2: $S \rightarrow bAaB$, $S \rightarrow \epsilon$

E2: $B \rightarrow S$, $S \rightarrow \epsilon$

E3: $B \rightarrow S$

E3: $B \rightarrow S$

Answer: (C)

Q. No. 56 – 60 Carry One Mark Each

56. The cost function for a product in a firm is given by $5q^2$, where q is the amount of production. The firm can sell the product at a market price of Rs.50 per unit. The number of units to be produced by the firm such that the profit is maximized is

(A) 5

(B) 10

(C) 15

(D) 25

Answer: (A)

Exp:- $P = 50q - 5q^2$

$\frac{dp}{dq} = 50 - 10q$; $\frac{d^2p}{dq^2} < 0$

$\therefore p$ is maximum at $50 - 10q = 0$ or, $q = 5$

Else check with options

57. Choose the most appropriate alternative from the options given below to complete the following sentence:

Suresh's dog is the one _____ was hurt in the stampede.

(A) that

(B) which

(C) who

(D) whom

Answer: (A)

58. Choose the grammatically **INCORRECT** sentence:
- (A) They gave us the money back less the service charges of Three Hundred rupees.
 (B) This country's expenditure is not less than that of Bangladesh.
 (C) The committee initially asked for a funding of Fifty Lakh rupees, but later settled for a lesser sum.
 (D) This country's expenditure on educational reforms is very less

Answer: (D)

59. Which one of the following options is the closest in meaning to the word given below?

Mitigate

- (A) Diminish (B) Divulge (C) Dedicate (D) Denote

Answer: (A)

60. Choose the most appropriate alternative from the options given below to complete the following sentence:

Despite several _____ the mission succeeded in its attempt to resolve the conflict.

- (A) attempts (B) setbacks (C) meetings (D) delegations

Answer: (B)

Q. No. 61 – 65 Carry Two Marks Each

61. Wanted Temporary, Part-time persons for the post of Field Interviewer to conduct personal interviews to collect and collate economic data. Requirements: High School-pass, must be available for Day, Evening and Saturday work. Transportation paid, expenses reimbursed.

Which one of the following is the best inference from the above advertisement?

- (A) Gender-discriminatory (B) Xenophobic
 (C) Not designed to make the post attractive
 (D) Not gender-discriminatory

Answer: (C)

Exp:-Gender is not mentioned in the advertisement and (B) clearly eliminated

62. Given the sequence of terms, AD CG FK JP, the next term is

- (A) OV (B) OW (C) PV (D) PW

Answer: (A)

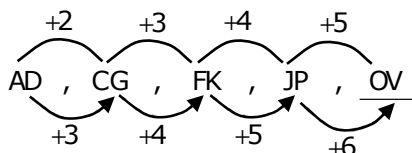

63. Which of the following assertions are CORRECT?
 P: Adding 7 to each entry in a list adds 7 to the mean of the list
 Q: Adding 7 to each entry in a list adds 7 to the standard deviation of the list
 R: Doubling each entry in a list doubles the mean of the list
 S: Doubling each entry in a list leaves the standard deviation of the list unchanged
 (A) P, Q (B) Q, R (C) P, R (D) R, S

Answer: (C)

Exp:- P and R always holds true

Else consider a sample set {1, 2, 3, 4} and check accordingly

64. An automobile plant contracted to buy shock absorbers from two suppliers X and Y. X supplies 60% and Y supplies 40% of the shock absorbers. All shock absorbers are subjected to a quality test. The ones that pass the quality test are considered reliable. Of X's shock absorbers, 96% are reliable. Of Y's shock absorbers, 72% are reliable.
 The probability that a randomly chosen shock absorber, which is found to be reliable, is made by Y is
 (A) 0.288 (B) 0.334 (C) 0.667 (D) 0.720

Answer: (B)

Exp:-

	x	y
Supply	60%	40%
Reliable	96%	72%
Overall	0.576	0.288
$\therefore P(x) = \frac{0.288}{0.576 + 0.288} = 0.334$		

65. A political party orders an arch for the entrance to the ground in which the annual convention is being held. The profile of the arch follows the equation $y = 2x - 0.1x^2$ where y is the height of the arch in meters. The maximum possible height of the arch is
 (A) 8 meters (B) 10 meters (C) 12 meters (D) 14 meters

Answer: (B)

Exp:- $y = 2x - 0.1x^2$

$$\frac{dy}{dx} = 2 - 0.2x$$

$$\frac{d^2y}{dx^2} < 0 \therefore y \text{ maximises at } 2 - 0.2x = 0$$

$$\Rightarrow x = 10$$

$$\therefore y = 20 - 10 = 10 \text{ m}$$